

Softclose:

8100V
8100H
8100M

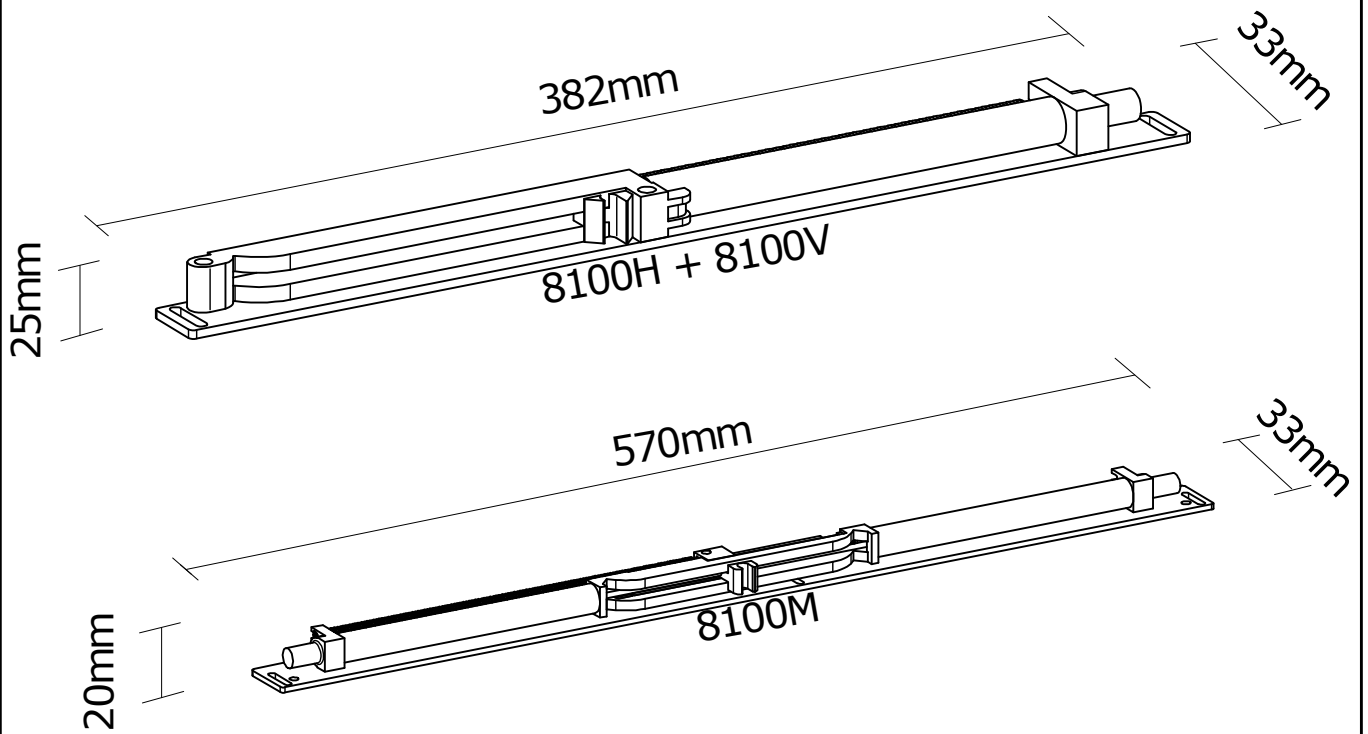

8100V

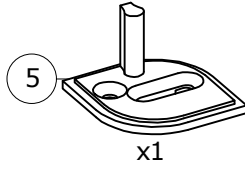
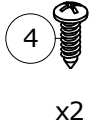
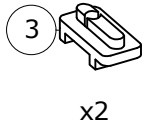
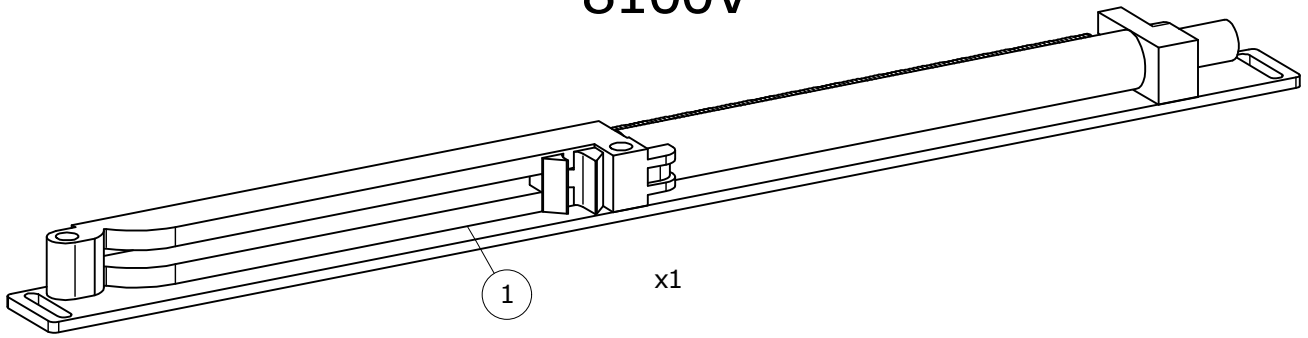

8100H

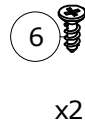
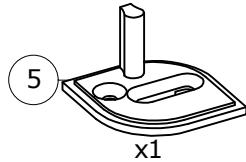
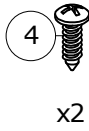
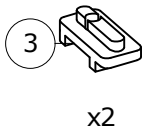
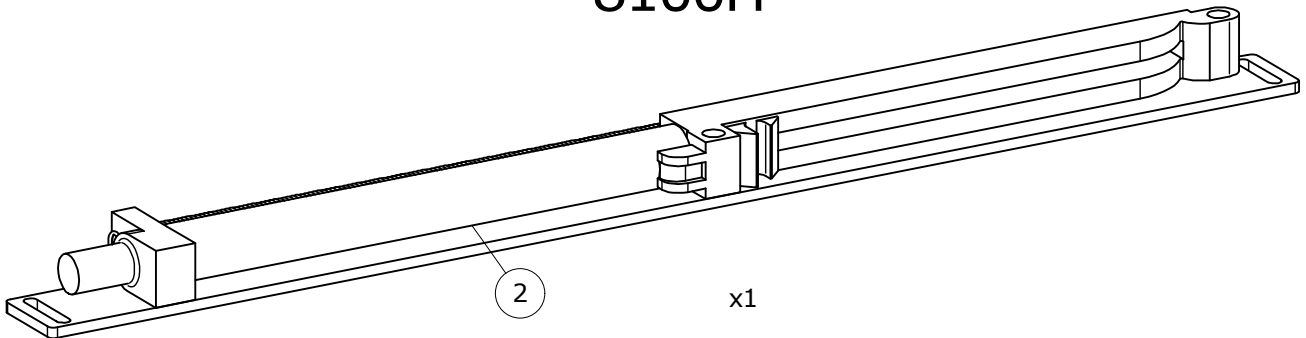

8100M

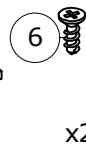
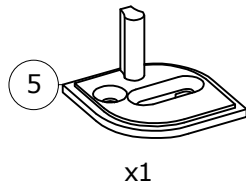
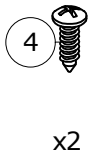
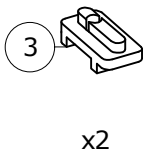
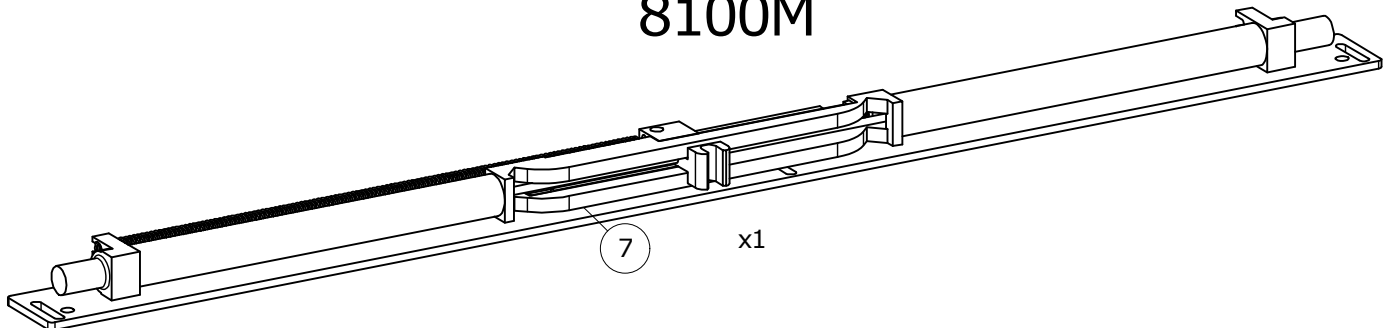

Del nr. 3 placeres mod venstre tophjul.
Det anbefales et forbore et $\varnothing 3\text{mm}$ hul til skruen.
Det er vigtigt at skruehul vender mod bagside af dør
(hvis ikke ødelægger skruen glasset/spejlet)

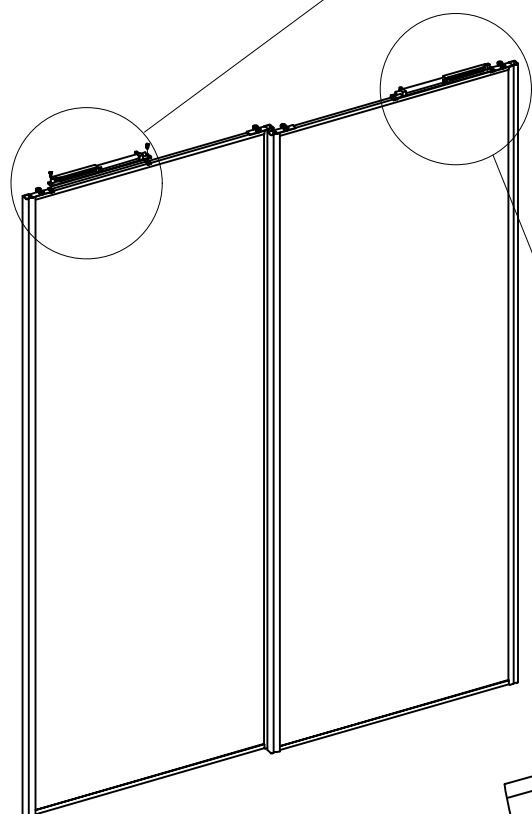
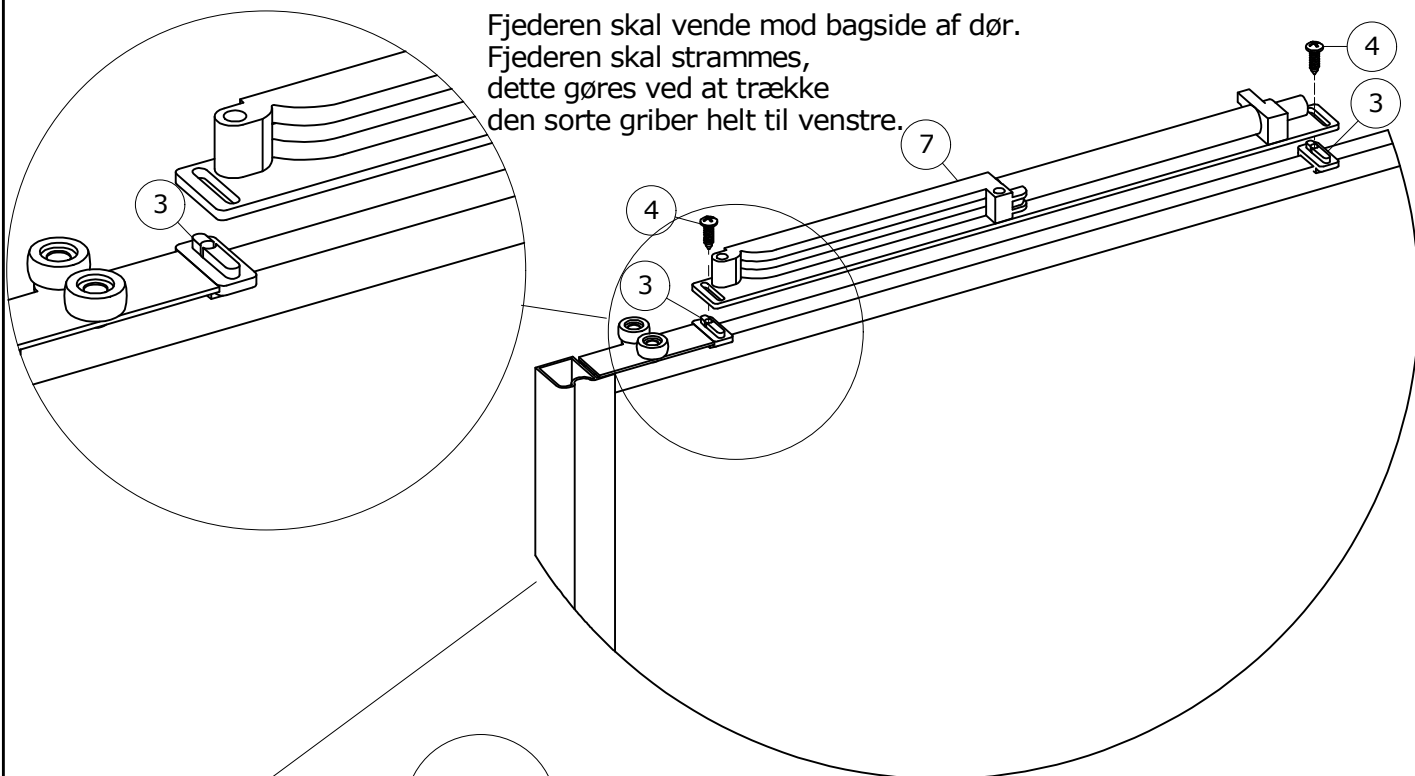

Del nr. 3 placeres mod højre tophjul.
Det anbefales et forbore et $\varnothing 3\text{mm}$ hul til skruen.
Det er vigtigt at skruehul vender mod bagside af dør
(hvis ikke ødelægger skruen glasset/spejlet)

Fjederen skal vende mod bagside af dør.
Fjederen skal strammes,
dette gøres ved at trække
den sorte griber helt til højre.

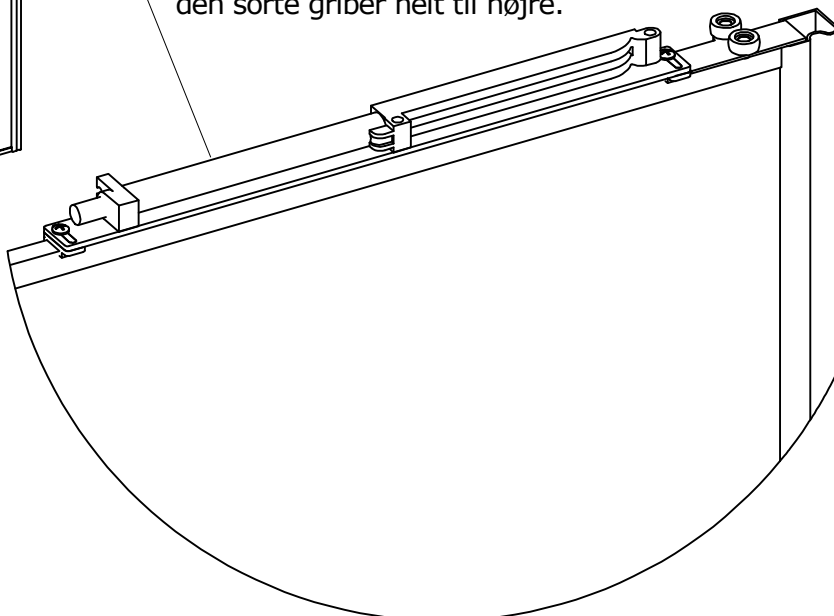

Del nr. 3 placeres i spor på beslag.
Det anbefales et forbore et $\varnothing 3\text{mm}$ hul til skruen.
Det er vigtigt at skruenhul vender mod bagside af dør
(hvis ikke ødelægger skruen glasset/spejlet)

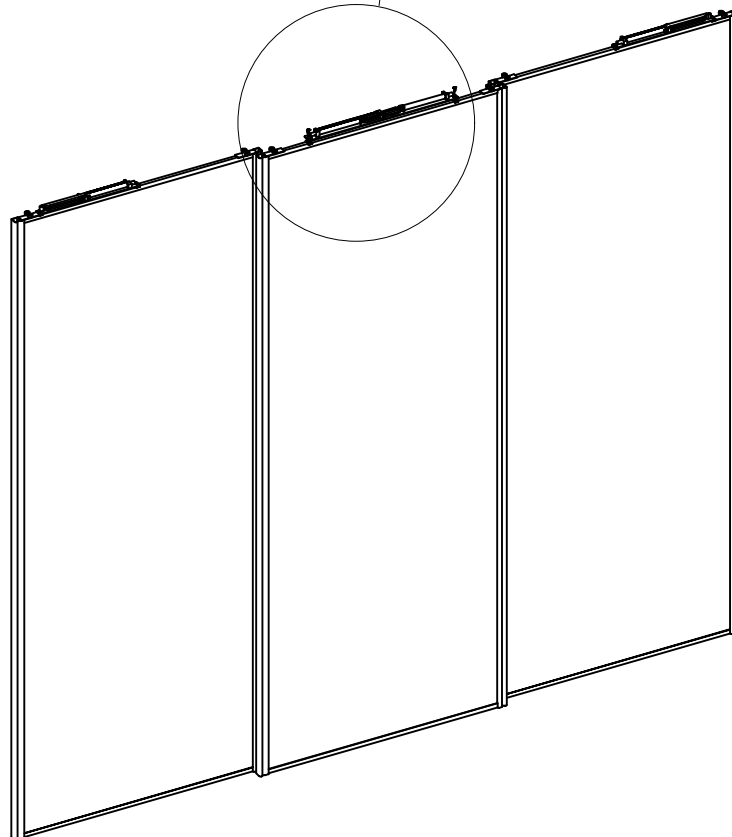
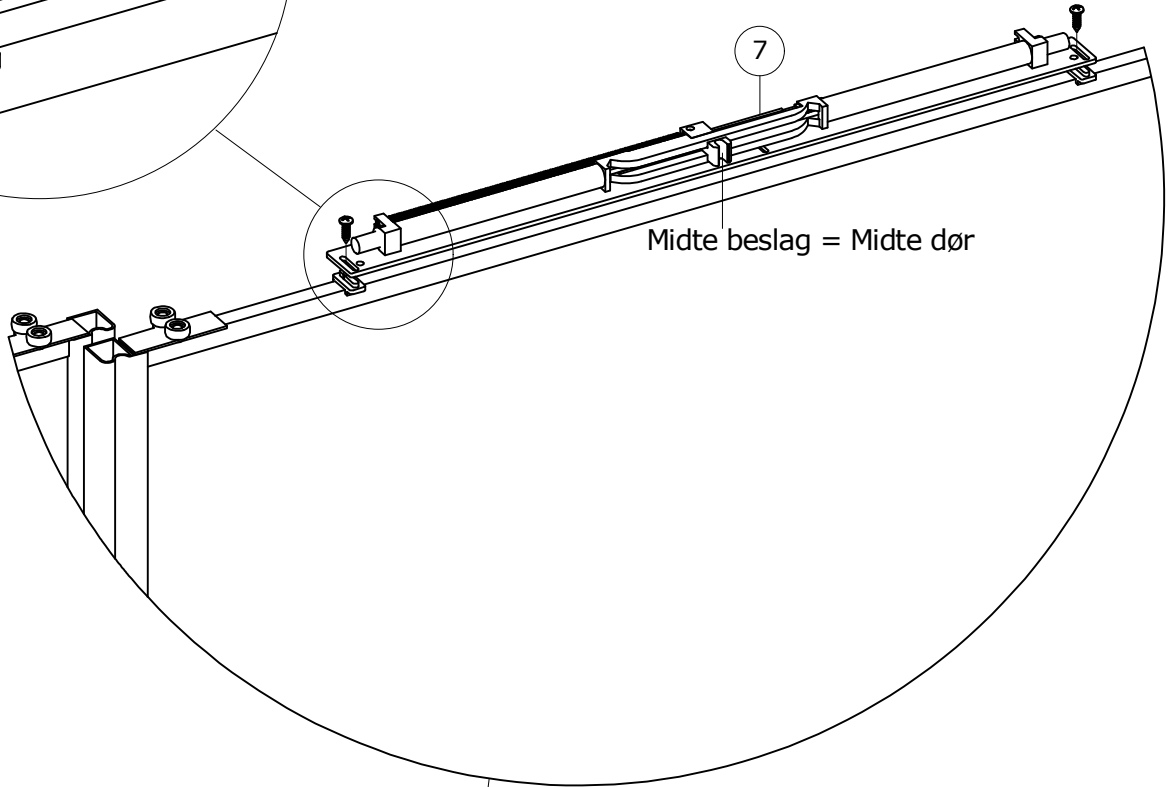
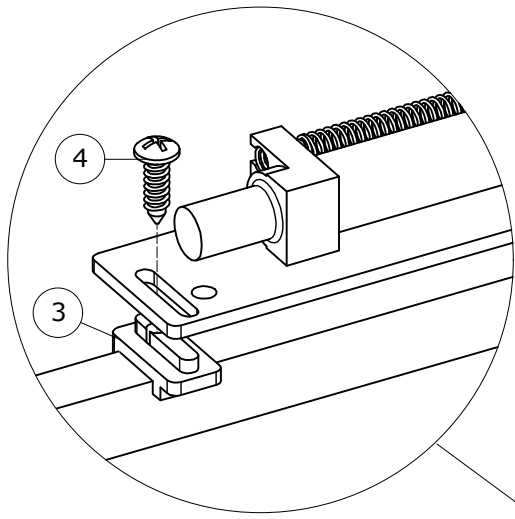

Der laves en streg 240mm fra skabssiden, i det spor hvor døren lukker mod siden. ved midterdør laves stregen midt på topskinnen.

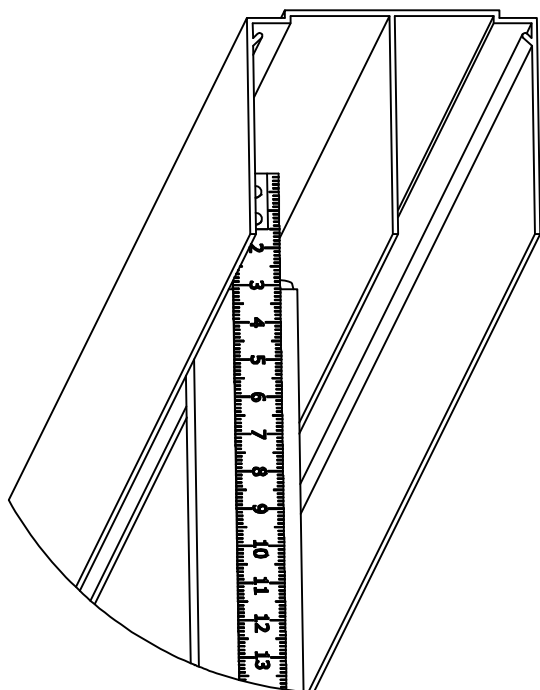

Skydedøre justeres.
Herefter måles afstand, (dør placeres ved streg) fra top af sideprofil på dør til bund af loftskinne, **OBS! min. afstand = 28mm** fra dette mål fratrækkes 19mm = længde på dørstop del nr.5 (eks. 31-19 = 12mm)

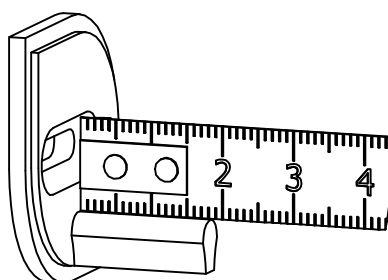

Dørstop afkortes, (eks. 12mm) længde måles som vist her.

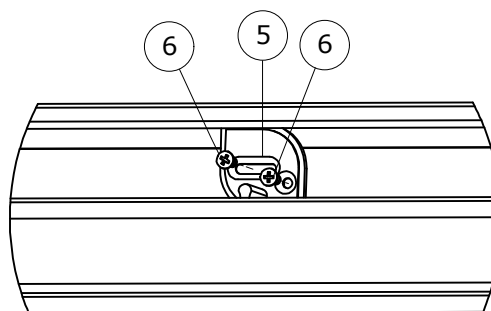
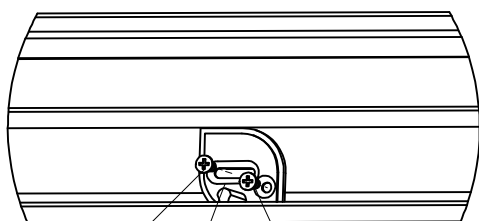

Dørstop placeres så den afkortede tap på del. 5 er ud for den før afmærkede streg, tap skal vende ud mod front. Skrues fast først i det aflange hul, (forbor med $\varnothing 3\text{mm}$) kan justeres i længderetningen hvis det er nødvendigt efter justering skrues den anden skrue i det runde hul.